

Tracked Paver

# SUPER 700(i) | SUPER 800(i)



# PERFECT IN ALL CLASSES

The right paver for every job

VÖGELE's seamless product range is considered unique in the industry. Whether a service road or a motorway, an airfield or a race track, a new construction or a rehabilitation job, thick or thin, hot or cold – customers will find the right machine in our paver range for every paving task.



## VÖGELE PRODUCT RANGE

- MINI CLASS**
  - > Maximum pave width 3.5 m
  - > Maximum laydown rate 300 t/h
- COMPACT CLASS**
  - > Maximum pave width 5 m
  - > Maximum laydown rate 350 t/h
- UNIVERSAL CLASS**
  - > Maximum pave width 10 m
  - > Maximum laydown rate 700 t/h
- HIGHWAY CLASS**
  - > Maximum pave width 18 m
  - > Maximum laydown rate 1800 t/h
- SPECIAL CLASS**
  - > SprayJet
  - > InLine Pave
- POWERFEEDER**
  - > MT 3000-3(i) Standard
  - > MT 3000-3(i) Offset

# HIGHLIGHT OVERVIEW

Perfectly equipped



## DRIVE

### 01 Future-proof drive technology

- > Powerful and cost-efficient thanks to the 55.4 kW diesel engine and ECO mode.
- > Positive tracking and precise steering delivered by traction drives in closed loops.

## OPERATING SYSTEM

### 02 ErgoBasic operating system

- > Innovative, easy-to-grasp ErgoBasic operating concept for simple handling.

### 03 Niveltronic Basic System for Automated Grade and Slope Control

- > Easy-to-operate system for automated grade and slope control.

## MATERIAL MANAGEMENT

### 04 Receipt of mix

- > Large material hopper with a capacity of 5.8 tonnes ensures optimum feeding with mix.
- > Hydraulically adjustable asymmetrical hopper side to simplify feeding with mix on cramped job sites.

### 05 Adjustable push-rollers

- > The possibility of adjusting the push-rollers to the left makes it easier for trucks to supply mix during paving along walls or other restrictions.

## VERSATILITY

### 06 Compact dimensions

- > Small dimensions make it suitable for use in the most confined job sites.

### 07 Pave widths

- > Large range of pave widths from 0.5 to 3.2 m on the SUPER 700(i) or 0.5 to 3.5 m on the SUPER 800(i) covers a variety of paving jobs.

### 08 Screeds

- > The SUPER 700(i) already achieves a good degree of precompaction using just the AB 200 V or the AB 220 V.
- > Outstanding precompaction can be achieved using the AB 200 TV and the AB 220 TV.



01



02



03



04



05



06

# SUPER 700(i) AND SUPER 800(i)

Great things come in small packages

**The compact dimensions, variable pave width and power of these two Mini Class pavers make them ideal for repairs and for paving small areas.**

The SUPER 700(i) and the SUPER 800(i) are extremely compact pavers which are suitable for a great many applications. Whether paving small paths, close to walls and kerbs, between tram rails or inside buildings, it is in precisely these cramped spaces that the Mini Class really comes into its own.

The two compact pavers are perfect for relatively small to medium-sized jobs such as backfilling trenches or creating footpaths and cycle ways. Landscaping contracts are other great strengths of these pavers. Paving floors inside factory halls or underground garages is very demanding on paver technology as it calls for a compact design and manoeuvrability.

When it comes to technology, the compact pavers can keep pace with the large Dash 3 pavers: their powerful material handling system is as sophisticated as their ErgoBasic operating concept.

The excellent price/performance ratio of these compact pavers is one of their greatest attractions. It makes them ideal machines for relatively small landscaping companies and for local authority operations.



**01** Large material hopper with a capacity of 5.8 t.  
**02** Traction drives in closed loops deliver both positive tracking when moving straight and precise steering.  
**03** Innovative, easy-to-operate ErgoBasic operating concept for simple handling.

**04** All the key paving functions can be controlled by the two handy remote control units for the screed.  
**05** Niveltronic Basic fully integrated automated grade and slope control.  
**06** Can be combined with the AB 200 and AB 220 Extending Screens.

# PRECISION IN SMALL SPACES

Paving as close as 5 cm from boundaries

**If a job site is particularly cramped, narrow or low, it is time for a VÖGELE Mini Class paver. Compact dimensions and excellent manoeuvrability make both Mini Class pavers the ideal machines for this.**

Mini Class pavers really come into their own for work on the central reservations of motorways, in underground garages and low-ceilinged factory halls. In these applications, their small dimensions, great manoeuvrability and power are key factors in efficient deployment.

These highly evolved pavers are perfectly equipped to handle even the most difficult conditions. The asymmetrical hopper side, for instance, allows Mini Class pavers to be fed with mix easily in extremely confined spaces.

- 01** With an external track gauge of just 1.14 m and the AB 200 Extending Screed with its basic width of just 1.1 m, the tracked paver is suitable for paving between tramway rails and in milled strips.
- 02** The small clearance width of 1.4 m means that even narrow entrances or gates are no longer an obstacle. The paver can pass through tight entrances and is capable of surfacing traffic areas in buildings such as underground car parks without any problem.

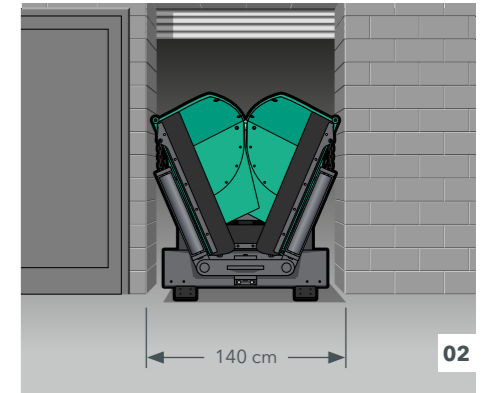
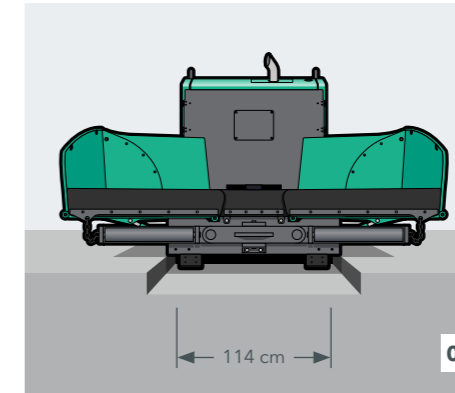

- 03** The sophisticated paver design allows machine-based paving as close as 5 cm from boundaries. The overall height of less than 2 m allows paving in height-restricted spaces and under canopies.
- 04** The great range of pave widths – from 0.5 to 3.5 m – means it can be used in a wide variety of applications, ensuring high utilization of the machine.

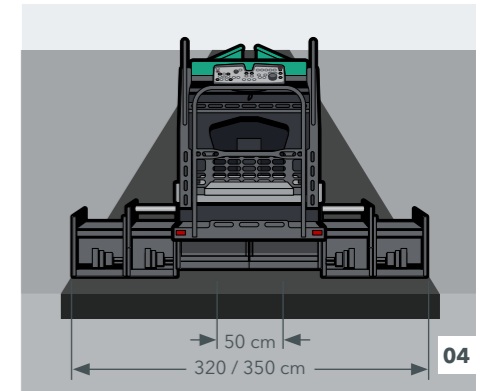
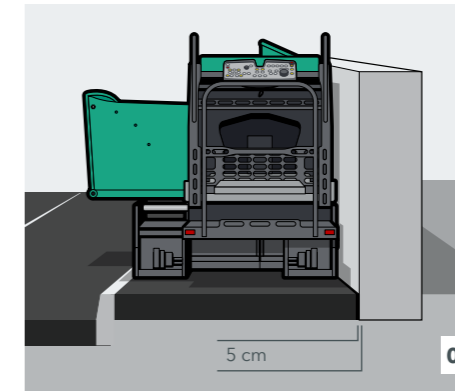

# SEVERAL FEEDING OPTIONS AND OPTIMAL FLOW OF MIX

Flexible feeding options are particularly useful when space is narrow and confined and is exactly what the large material hopper of VÖGELE Mini Class pavers was designed for. Depending on the space available, they can be conveniently supplied with mix by truck or excavator.

The large material hopper with separately folding sides is designed so that the machine can always be supplied with paving material in the best, most cost-effective way. The optional asymmetrical hopper (on the left) allows the paver to be supplied with material by truck even if the feed vehicle is unable to dock centrally in front of the machine, as is the case when paving along walls or other boundaries, for instance.

The pavers of the Mini Class come with a powerful material handling system. The large material hopper holds an ample supply of mix, while the wide conveyor tunnel permits a high material throughput. The large auger blades ensure that the material is spread evenly in front of the screed.

**Material hopper with a capacity of 5.8 t**  
with separately adjustable sides for ideal feeding with mix

**Wide conveyor tunnel**  
for a high throughput of mix



01 Material hopper with a volume of 5.8 t  
02 Reversible conveyor  
03 Large conveyor tunnel  
04 Asymmetrical hopper side

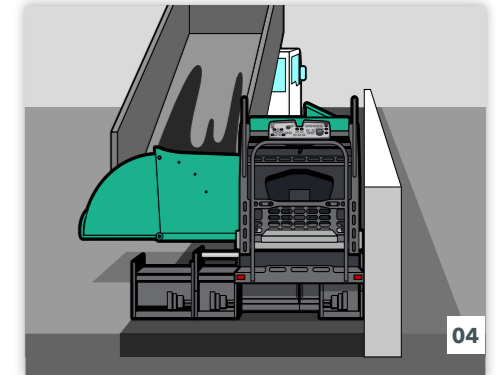
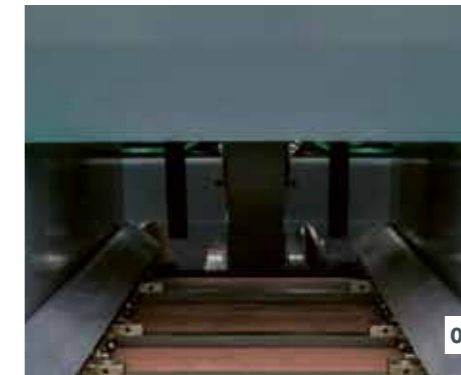

The arrangement of the conveyor drive at the rear of the machine makes for optimum power transmission, ensuring a high conveying capacity while minimizing wear of paver components. The conveyor is reversible, preventing any spills

of material when repositioning the paver on the job site. The conveyor tunnel is wide enough to guarantee a high material throughput of up to 300 t/h.

## VÖGELE > GOOD TO KNOW

### Adjustable auger height

With a diameter of 30 cm, the large auger blades ensure that the mix is spread homogeneously. The height of the augers is infinitely variable by 10 cm - even hydraulically on request.

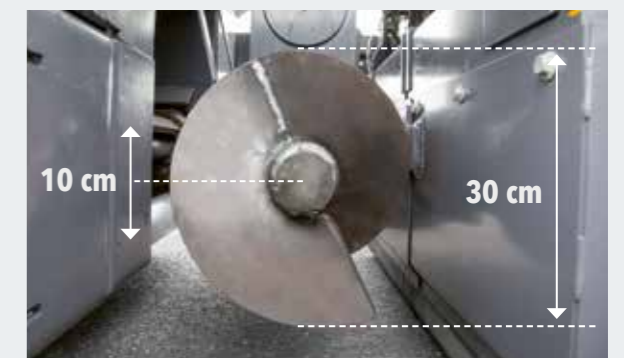



## THE ERGOBASIC OPERATING CONCEPT

Full control for the driver and operator

The ErgoBasic operating concept was developed on the basis of the proven ErgoPlus operating system and tailored specifically to the needs and requirements of Mini Class pavers. It concentrates on the key functions.

The aim was to develop an operating system for the small machines that is just as quick, precise and intuitive to operate as the system for our large machines. This makes VÖGELE the only manufacturer to offer a standardised operating concept for all paver classes.



# THE PAVER OPERATOR'S ERGOBASIC CONSOLE

Clearly arranged in line with experience from the field

Everything at a glance: the functions are arranged in a clear, logical and practical layout that has clearly been inspired by the ErgoPlus operating console. The type of controls and the symbols used are all in line with those of an ErgoPlus console but have been tailored to the functions of a small paver.

Given the limited number of functions, there is no need for a display. The status of all settings is indicated as a percentage on LED strips immediately next to the relevant functions.

LEDs also indicate the set speeds for the augers and the compacting systems as well as the fill level of the fuel tank.



## Safe operation during the night

The paver operator's ErgoBasic console features glarefree backlighting so that the paver operator can also work safely on night-time jobs.

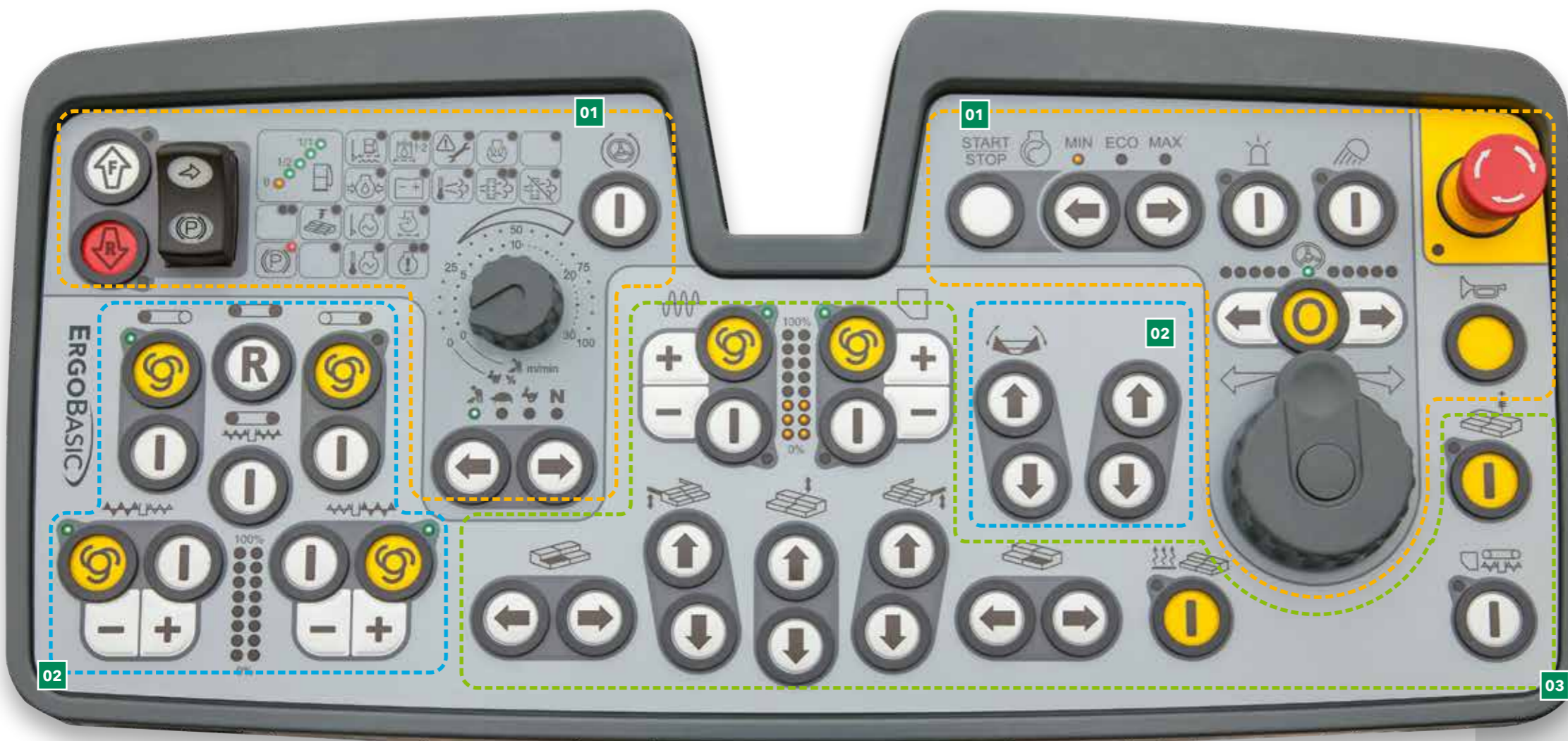

### 01 Drive and status display function group

All the functions for driving the paver are collected together here. The status displays also provide an overview of paver status.

### 02 Material handling function group

The material handling function group includes operation of the hopper sides and for conveyor and auger.

### 03 Screed function group

This function group contains all the screed functions, including the settings for tamper and vibrators and adjustment of screed width and pitch.



# DRIVE AND STATUS DISPLAYS

## Function group 1

### 01 Choice of operating modes

At the touch of a button, the paver switches to Pave, Positioning, Job Site and Neutral modes. An LED indicates which mode is selected. When Pave mode is exited, the memory function saves all the values last set. After the paver moves on the job site, the previously used paving parameters are thus instantly restored.

### 02 Steering at a preselected steering angle

The machine is steered by means of a rotary controller which enables the paver operator to manoeuvre the machine precisely even in the tightest spots. For long curves with a constant radius, the desired steering angle can be preselected using arrow keys. The paver automatically stays on the set track until the function is deactivated, allowing the paver operator to monitor the paving process undisturbed.



**01** At the touch of a button, the paver switches between Pave, Positioning, Job Site and Neutral modes.

**02** The machine is steered by a rotary controller for simple, precise manoeuvring.



### 03 Function and status indicators

The function and status indicators mean that the operator always has full control over his machine, even without a display. He can, for instance, read the fill level of the fuel tank directly and identify whether there are any functional faults.

### 04 Choice of engine speed ranges

There are three speed ranges for the diesel engine: MIN, ECO and MAX. The desired range can be set easily using the arrow keys. Many construction projects can be completed at ECO rpm. The lower engine speed reduces noise emissions considerably and saves fuel.

# MATERIAL MANAGEMENT

## Module 2

### 01 Speed of the augers

In automatic mode, the maximum speed of the augers can be adapted to pave width separately for the left and right using the plus and minus keys. The set value is displayed as a percentage on the LED strip.

### 02 Reverse conveyor movement

In order to prevent soiling as a result of mix dropping off the conveyor when the paver is repositioned on the job site, conveyor movement can be reversed at the touch of a button - at the end of a section, for example. Reverse movement takes place for a short time only and stops automatically.



The conveyor can be reversed at the touch of a button. Return transport of the mix is automatically stopped. The conveyor can be switched to the no-load function just as quickly.



### 03 Automatic functions for material handling/distribution

These functions ensure that enough mix for paving is automatically conveyed and distributed in front of the screed. A material sensor defines the height of the head of mix and the automatic system ensures that this remains constant. The function is only active during paving - if the paver stops, so does material handling.

# SCREED FUNCTIONS

## Module 3

### 01 Precompaction performance

The speeds of the compacting systems can be set directly on the operator's console. The LED strips from 0 to 100% indicate the set speeds for the tamper and vibrators, allowing them to be adjusted immediately when required.

### 02 Screed Assist (option)

This is used to switch Screed Assist on and off. Assist pressure and balance can be adjusted on the display. Screed Assist is active only when the screed is floating.



01 Compacting effort  
02 Screed Assist (option)  
03 Screed settings



### 03 Screed settings

All the important screed settings can also be made from the paver operator's console - including raising or lowering the screed, extending or retracting either side of the screed and adjusting screed pitch to suit site conditions. This means that the paver operator, too, has access to the screed at all times.

### 04 Idling function

Idling function allows the machine to warm up or conveyors, augers and tampers to be cleaned.

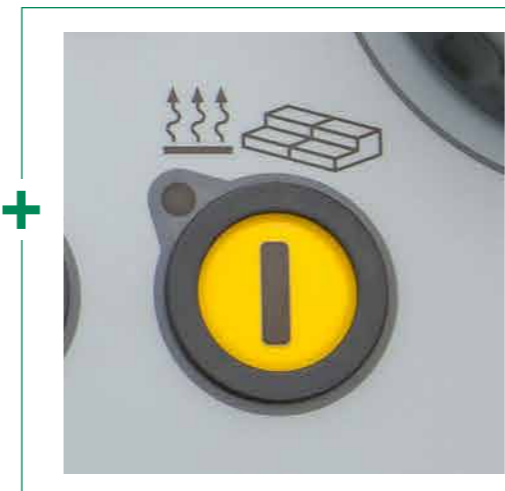

### Screed Heating

In order to optimise compaction and produce a smooth surface texture, all compacting elements are heated across full screed width. A simple touch of a button is all it takes to switch screed heating on or off. To ensure the screed heating system is working properly, an automatic function check is carried out when it is switched on.

# THE ERGOBASIC REMOTE CONTROL UNIT FOR THE SCREED

Simple, reliable handling of all screed functions is a key factor in high-quality asphalt paving, which is why an ErgoBasic screed remote control unit was developed especially for the operating system of these compact pavers. Its keypad is arranged logically to suit functional processes and its robust design is well able to withstand harsh job site conditions.

Operation is easy to understand and can thus be learned intuitively in a very short space of time, not least because the symbols used were adopted from the proven ErgoPlus operating concept.

The ErgoBasic screed operator's console allows all the functions relevant to paving to be adjusted quickly and easily. These also include direct access to the material handling systems and the sonic sensor for the auger.



## 01 Auger output

In automatic mode, the maximum speed of the augers can be adapted to pave width separately using the plus and minus keys. The set value is displayed as a percentage on the LED strip.



## 02 Screed Float on/off

The screed can be made to float at the touch of a button.



## 03 Screed width control

The screed width on one side can be adjusted at any time at the push of a button.



Shown in original size

- 01 Auger, automatic/manual/ reverse
- 02 Screed floating on/off
- 03 Screed width control, one side
- 04 Adjustment of screed tow point ram

There is a remote control unit for each side of the screed. The magnetic brackets and connection by means of a coiled cable give the operator a large range of operation, so that he can always operate the screed from the best possible position; this is of particular importance when working in confined job site conditions.

# NIVELTRONIC BASIC

**VÖGELE has also developed a System for Automated Grade and Slope Control to match the ErgoBasic operating system: Niveltronic Basic. It is completely integrated in the machine control system and therefore perfectly adapted to the paver model concerned.**

An outstanding aspect of Niveltronic Basic is its particularly simple and intuitive handling, a feature which makes it easy even for less experienced operators to learn to use the system correctly. This creates ideal conditions for the compact pavers to work true to line and level on any terrain.

Each side of the screed is operated by a separate compact and highly robust Niveltronic Basic remote control unit. These units are easily removed from their magnetic brackets, giving the operator a large range of operation, so that he can always adopt the optimum position for every paving situation.



01



02



03

- 01 The LED sighting crosses fitted to the sensor provide continuous, clearly visible feedback to the screed operator indicating whether actual values match the settings made.
- 02 A variety of sensor types is available for Niveltronic Basic to suit the variety of applications for the paver. The sensors range from mechanical to non-contacting sonic sensors.
- 03 The pre-set and actual values for the grade and slope control sensor can be read off the display of the Niveltronic Basic control console.



- 01 Deviation from specified values
- 02 Setting: sensor sensitivity
- 03 Selecting: kind of reference (ground, tensioned wire, transverse slope)
- 04 Quick set-up
- 05 Sensor calibration

## VÖGELE > GOOD TO KNOW



### Sensors available

#### Slope sensor

The slope sensor allows the transverse profile to be determined exactly and then paved accurately. The measuring range is +/- 10%.

#### Variable mechanical grade sensor

The variable mechanical grade sensor can be equipped with skis for referencing from the ground in 30 cm, 1 m and 2 m lengths.

#### Single-cell sonic sensor

The single-cell sonic sensor emits a sound cone and consequently copies references 1:1 without calculating an average. It can be used for referencing from the ground (Ground mode) or from a tensioned wire (Stringline mode).

#### Multi-cell sonic sensor

The multi-cell sonic sensor, with its four sensors, is highly versatile. By calculating an average, it can compensate for short irregularities in a reference.

# FUTURE-PROOF DRIVE TECHNOLOGY

Three main components form the power unit of compact pavers: the modern, liquid-cooled diesel engine, a splitter gearbox flanged directly to the engine and a large cooler assembly.

The driving force in this power pack from VÖGELE is its high-performance diesel engine. The four-cylinder engine delivers 55.4 kW at 2,200 rpm, though fuel-saving ECO mode is sufficient for many applications. Even then, the paver still has a full 54 kW at its disposal. Moreover, the machine generates even less noise when running at just 1,800 rpm.

A large cooler assembly ensures that the power unit always delivers its full output. With innovative air routing and a

variable-speed fan, temperatures are continuously maintained within the optimum range, significantly extending the service life of both the diesel engine and the hydraulic oil. A further advantage is that the machine can operate without difficulty in all climate regions worldwide.

All the hydraulic consumers are directly supplied with hydraulic oil via the splitter gearbox. Hydraulic pumps and valves are centrally located, making them perfectly accessible for servicing.

**Modern diesel engine**  
with an output of 55.4 kW at 2,200 rpm

**ECO mode at 1,800 rpm**  
reduces fuel consumption

**Large cooler assembly**  
for perfect cooling with low noise

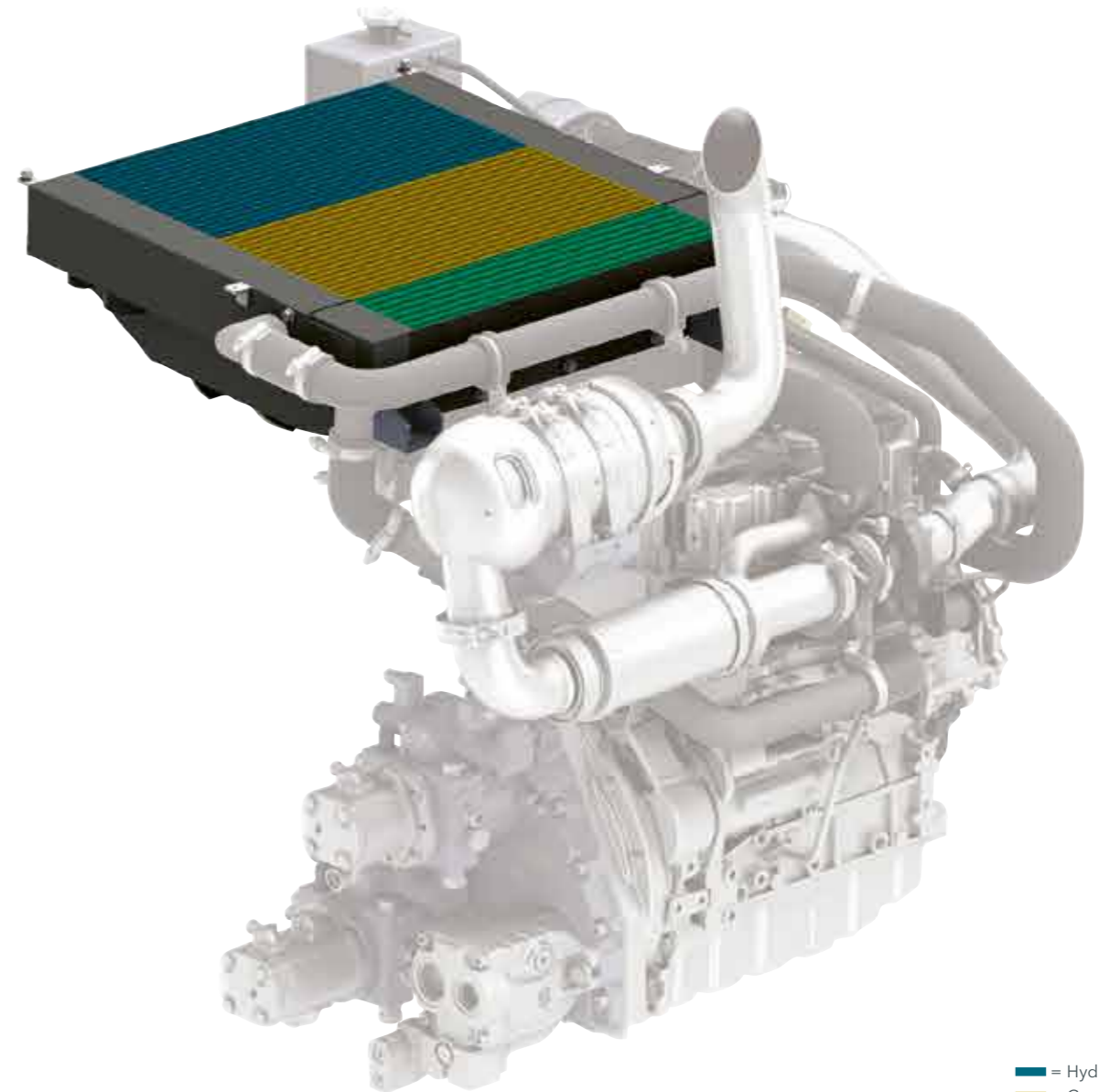

■ = Hydraulic oil  
■ = Coolant  
■ = Charge air

A large cooler assembly with innovative air routing is installed for perfect cooling of the engine coolant, hydraulic oil and charge air in every climate zone in the world.

This ensures that the diesel engine can deliver maximum output and helps prolong its service life.

## VÖGELE > GOOD TO KNOW

### Powerful diesel engine with efficient exhaust emissions after-treatment

Machines with the suffix "i" in the product name are not only economical, but also extremely clean. The "i" stands for intelligent emission control and is found in the type names of all WIRTGEN GROUP machines equipped with the latest engine technology. Depending on the design of their exhaust gas after-treatment, these engines comply with the strict standards of European exhaust emissions Stage V as well as US standard EPA Tier 4f.

A version without exhaust emissions after-treatment is available for less regulated markets. This engine meets European exhaust emissions Stage 3a and US standard EPA Tier 3.

# PRECISION ON TRACKS

Separate high-quality hydraulic drives are a key component of the VÖGELE drive concept. They make our pavers immensely efficient and economical.

- > Positive tracking when moving straight and accurate cornering are delivered by the separate drive and electronic control provided for each crawler track.
- > Powerful separate drives fitted into the sprockets of the crawler tracks enable engine output to be translated into pave speed with no loss of power.
- > The long crawler tracks have a large footprint to deliver maximum traction. This ensures a constant forward speed, even when operating on difficult terrain.

**Powerful separate drives**  
fitted into the sprockets of the crawler tracks

**Consistent positive tracking when moving straight**  
as a result of separate electronically-controlled drives



# IDENTICAL SERVICE CONCEPT



The standardized service concept conceived for the VÖGELE pavers means that servicing is quick and uncomplicated. Large hinged panels provide convenient access to all service points on the machine.

All hydraulic pumps are located on the splitter gearbox and their clear arrangement and easy accessibility provide maximum ease of servicing. Wear-resistant components also guarantee a long service life.



# AB 200 AND AB 220 EXTENDING SCREEDS

The AB 200 Extending Screed and the AB 220 Extending Screed were designed specifically for use with the SUPER 700(i) and SUPER 800(i). The extending screeds play specifically to the strengths of this Mini Class paver. Not only do they deliver the greatest possible flexibility, they also meet VÖGELE's own quality standards.

The AB 200 Extending Screed has a basic width of just 1.1 m and extends hydraulically up to 2 m. It is ideal for paving narrow paths and paving between rails or in milled strips. The AB 220 Extending Screed is available for rather larger projects. With a basic width of 1.2 m, it extends hydraulically to 2.2 m. If bolt-on extensions are mounted, the maximum width is as much as 3.5 m.

The system for pave width reduction allows pave width to be reduced infinitely to 0.5 m. Once fitted, this is conveniently effected from the paver operator's stand without any need for conversion.

The system for pave width reduction makes it child's play to backfill trenches or pave asymmetrically along kerbs or walls, even when using joint tape.

**Variable pave widths**  
from 1.1 to 2.2 m with the AB 220

**Uniform screed heating**  
of screed plates and tamper for uniform surface courses

**Alternating mode for screed heating**  
alternately powering each half of the screed heating system



## AB 200

### Pave widths

- > Infinitely variable range from 1.1 m to 2 m
- > Maximum pave width with bolt-on extensions:
  - > 3.2 m (2 x 60 cm)
- > Minimum pave width of 0.5 m with system for pave width reduction

### Compacting systems

- SUPER 700(i): AB 200 V with vibrators
- SUPER 800(i): AB 200 TV with tamper and vibrators

## AB 220

### Pave widths

- > Infinitely variable range from 1.2 m to 2.2 m
- > Maximum pave width with bolt-on extensions:
  - > SUPER 700(i): 3.2 m (2 x 50 cm)
  - > SUPER 800(i): 3.5 m (2 x 65 cm)
- > Minimum pave width of 0.5 m with system for pave width reduction

### Compacting systems

- SUPER 700(i): AB 220 V with vibrators
- SUPER 800(i): AB 220 TV with tamper and vibrators

## AB 200

AB 200 TV with 60 cm bolt-on extensions

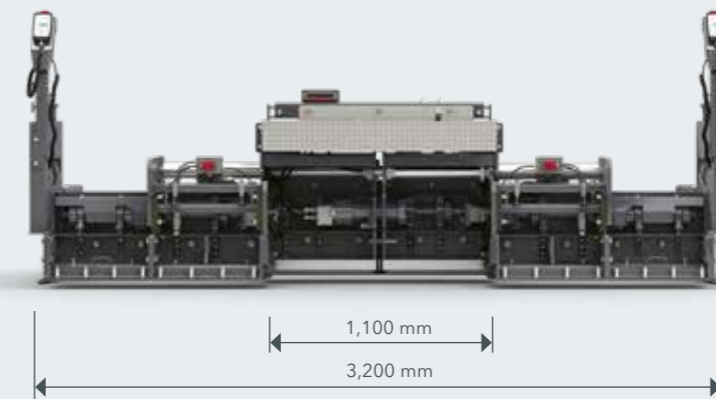

## AB 220

AB 220 TV with 65 cm bolt-on extensions

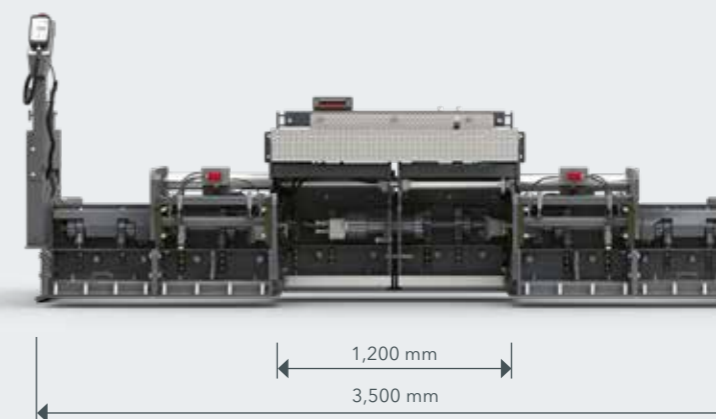



# ALL THE FACTS AT A GLANCE

SUPER 700(i) and SUPER 800(i) Tracked Paver



## TECHNICAL DATA

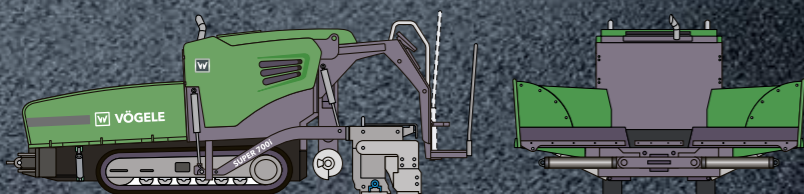

### SUPER 700(i)

- > Pave widths: 0.5-3.2 m
- > Maximum laydown rate 250 t/h
- > Layer thickness up to 15 cm
- > Clearance width 1.4 m

## TECHNICAL DATA

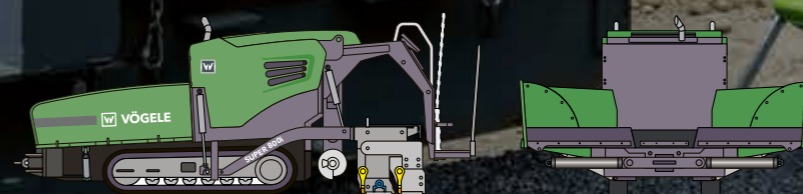

### SUPER 800(i)

- > Pave widths: 0.5-3.5 m
- > Maximum laydown rate 300 t/h
- > Layer thickness up to 20 cm
- > Clearance width 1.4 m

# WIRTGEN GROUP CUSTOMER SUPPORT

Service you can rely on.

You can have confidence in reliable, swift support from us during the entire life cycle of your machine. Our wide range of services is ready with the right solution to every challenge you face.



## Service

We keep our service promise with swift, straightforward assistance - on the job site or at our professional workshops. Our service team is trained to a professional standard and dedicated tools ensure that repair, care and maintenance tasks are completed quickly. We can support you with customised service agreements on request.

> [www.wirtgen-group.com/service](http://www.wirtgen-group.com/service)



## Spare Parts

WIRTGEN GROUP original parts and accessories assure the long-term reliability and availability of your machines. Our experts will also be pleased to advise you about optimised wear part solutions to suit your application. Our parts are available all over the world at all times and are easy to order.

> [parts.wirtgen-group.com](http://parts.wirtgen-group.com)



## Training

The WIRTGEN GROUP brands are specialists in their field with decades of experience in applications; our customers benefit from this expertise. In our WIRTGEN GROUP training courses, we are delighted to pass our knowledge on to you, customised to suit both operators and servicing staff.

> [www.wirtgen-group.com/training](http://www.wirtgen-group.com/training)



## Telematics solutions

At the WIRTGEN GROUP, construction machinery involving leading-edge technology goes hand in hand with sophisticated telematics solutions. Intelligent monitoring systems such as WITOS or JD Link\* not only make it easier for you to plan the maintenance of your machines, they also increase productivity and efficiency.

> [www.wirtgen-group.com/telematics](http://www.wirtgen-group.com/telematics)

\* Neither WITOS nor JD Link are currently available in all countries. Please contact the subsidiary or dealer responsible for you for more information about this.



**JOSEPH VÖGELE AG**

Joseph-Vögele-Str. 1  
67075 Ludwigshafen  
Germany

T: +49 621 8105-0

F: +49 621 8105-461

M: [marketing@voegele.info](mailto:marketing@voegele.info)

 [www.voegele.info](http://www.voegele.info)



For more information, scan the QR code.